

L:
 CBL-RTD3SABB-6m 6000mm±30mm
 CBL-RTD3SABB-7m 7000mm±30mm
 CBL-RTD3SABB-8m 8000mm±30mm

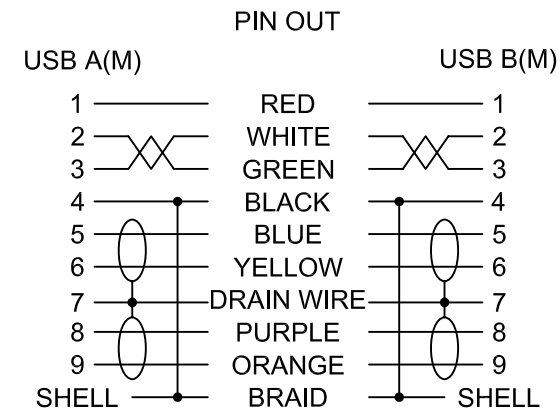

No	MATERIALS LIST:
1.	CABLE: 3 x (2 x 26 AWG)ST + 2 x 24 AWG O.D.:8.0mm COLOR:BLACK
2.	CONNECTOR:USB 3.0 A/M, 9P, BLUE INSULATOR SOLDER TYPE, NICKEL PLATED SHELL
3.	CONNECTOR:USB 3.0 B/M, 9P, BLUE INSULATOR SOLDER TYPE, NICKEL PLATED SHELL
4.	PVC MOLDED HOUSING, BLACK COLOR
5.	ABS ASSEMBLY HOUSING, BLACK COLOR

Jargy part no.	Client part no.	Approved	SCALE	UNIT
CBL-RTD3SABB-xm				mm
Drawing Name		Drawn	Date	REV.
USB 3.0 A to B Cable M/M				1.0

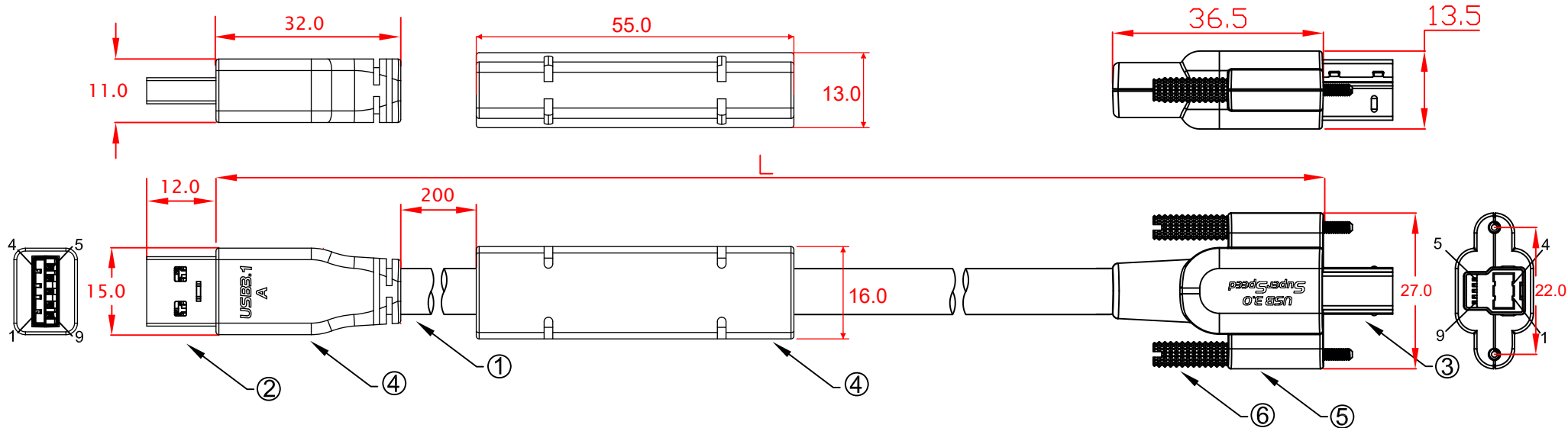

L:
 CBL-RTD3SABBS-6m 6000mm±30mm
 CBL-RTD3SABBS-7m 7000mm±30mm
 CBL-RTD3SABBS-8m 8000mm±30mm

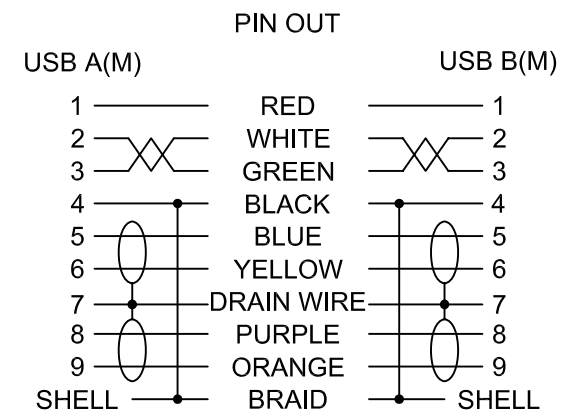

No	MATERIALS LIST:
1.	CABLE: 3 x (2 x 26 AWG)ST + 2 x 24 AWG O.D.:8.0mm COLOR:BLACK
2.	CONNECTOR:USB 3.0 A/M, 9P, BLUE INSULATOR SOLDER TYPE, NICKEL PLATED SHELL
3.	CONNECTOR:USB 3.0 B/M, 9P, BLUE INSULATOR SOLDER TYPE, NICKEL PLATED SHELL
4.	PVC MOLDED HOUSING, BLACK COLOR
5.	ABS ASSEMBLY HOUSING, BLACK COLOR
6.	SCREW:#4x34.5 M2

Jargy part no.	Client part no.	Approved	SCALE	UNIT
CBL-RTD3SABBS-xm				mm
Drawing Name		Drawn	Date	REV.
USB 3.0 A to B Cable M/M				1.0

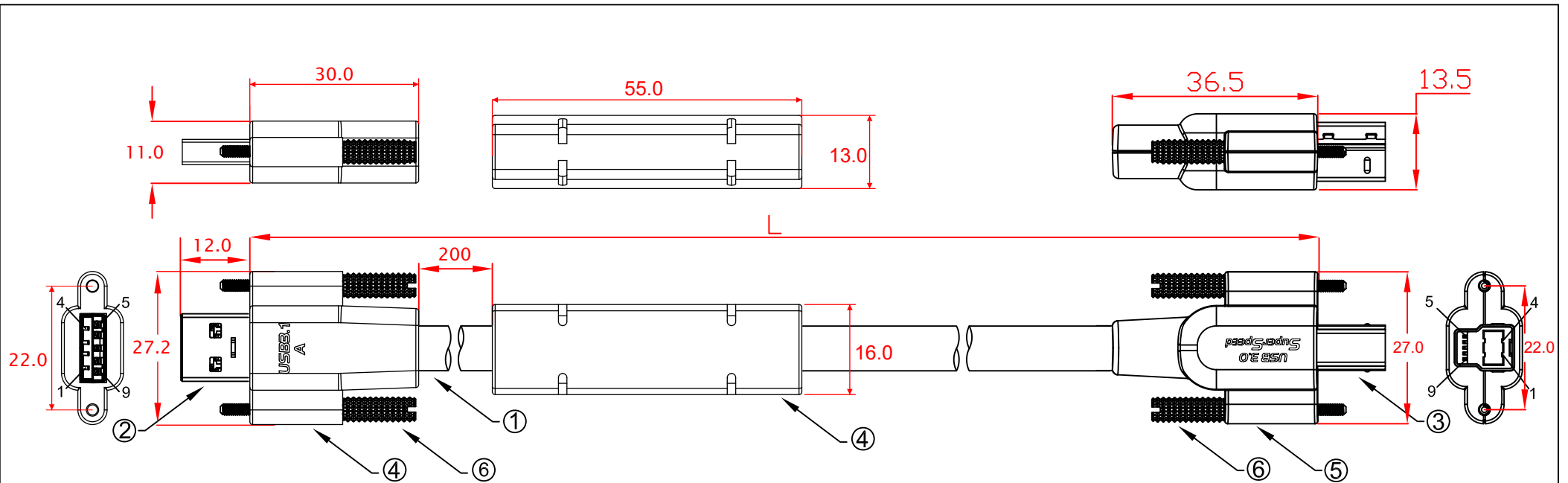

L:
 CBL-RTD3SABBSS-6m 6000mm±30mm
 CBL-RTD3SABBSS-7m 7000mm±30mm
 CBL-RTD3SABBSS-8m 8000mm±30mm

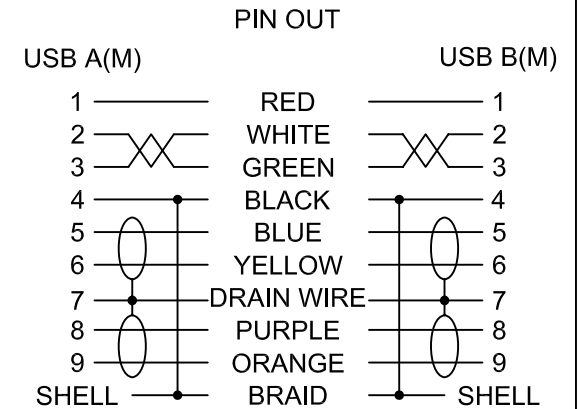

No	MATERIALS LIST:
1.	CABLE: 3 x (2 x 26 AWG)ST + 2 x 24 AWG O.D.:8.0mm COLOR:BLACK
2.	CONNECTOR:USB 3.0 A/M, 9P, BLUE INSULATOR SOLDER TYPE, NICKEL PLATED SHELL
3.	CONNECTOR:USB 3.0 B/M, 9P, BLUE INSULATOR SOLDER TYPE, NICKEL PLATED SHELL
4.	PVC MOLDED HOUSING, BLACK COLOR
5.	ABS ASSEMBLY HOUSING, BLACK COLOR
6.	SCREW:#4x34.5 M2

Jargy part no.	Client part no.	Approved	SCALE	UNIT
CBL-RTD3SABBSS-xm				mm
Drawing Name		Drawn	Date	REV.
USB 3.0 A to B Cable M/M				1.0

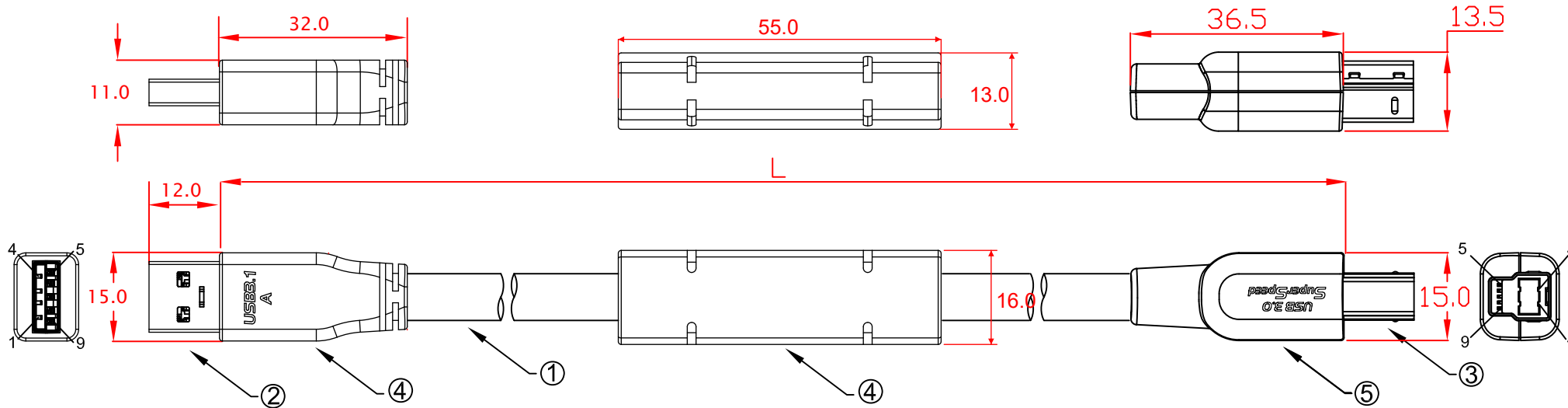

L:

CBL-RTD3SABB-9m	9000mm±30mm
CBL-RTD3SABB-10m	10000mm±30mm
CBL-RTD3SABB-11m	11000mm±30mm
CBL-RTD3SABB-12m	12000mm±30mm

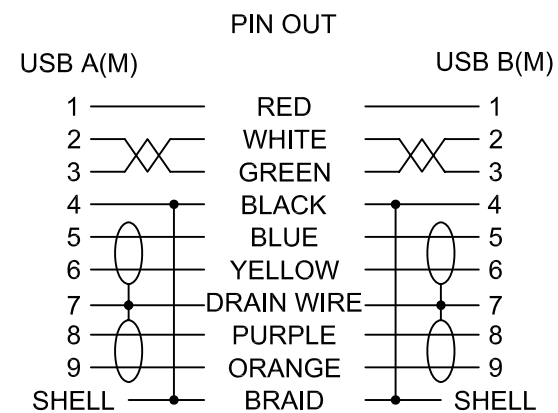

No	MATERIALS LIST:
1.	CABLE: 3 x (2 x 26 AWG)ST + 2 x 24 AWG O.D.:8.0mm COLOR:BLACK
2.	CONNECTOR:USB 3.0 A/M, 9P, BLUE INSULATOR SOLDER TYPE, NICKEL PLATED SHELL
3.	CONNECTOR:USB 3.0 B/M, 9P, BLUE INSULATOR SOLDER TYPE, NICKEL PLATED SHELL
4.	PVC MOLDED HOUSING, BLACK COLOR
5.	ABS ASSEMBLY HOUSING, BLACK COLOR

Jargy part no.	Client part no.	Approved	SCALE	UNIT
CBL-RTD3SABB-xm				mm
Drawing Name		Drawn	Date	REV.
USB 3.0 A to B Cable M/M				1.0

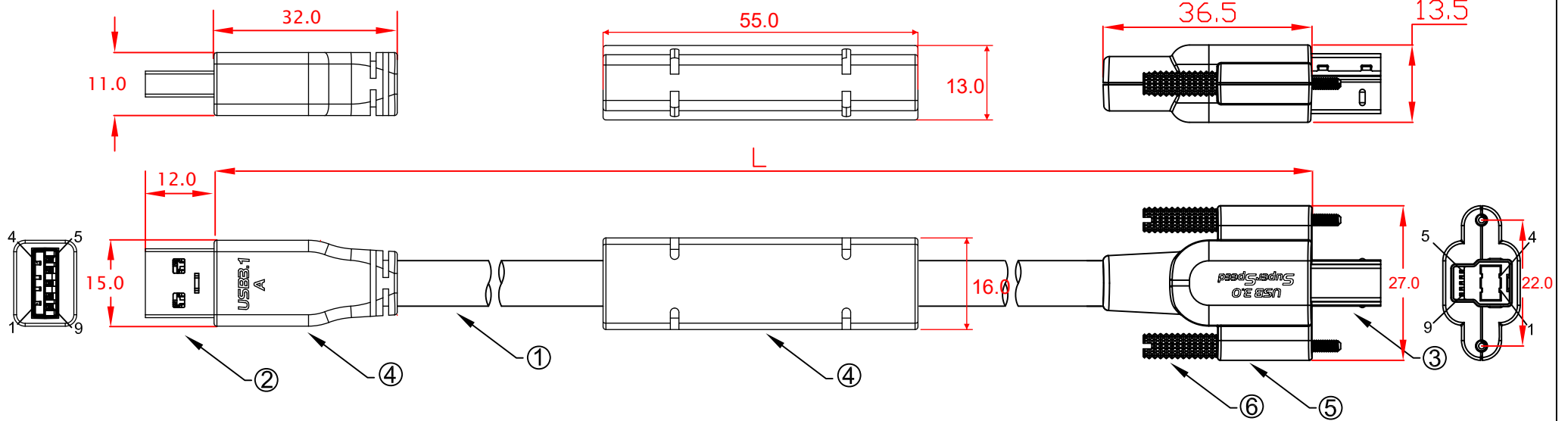

L:

CBL-RTD3SABBS-9m	9000mm±30mm
CBL-RTD3SABBS-10m	10000mm±30mm
CBL-RTD3SABBS-11m	11000mm±30mm
CBL-RTD3SABBS-12m	12000mm±30mm

PIN OUT

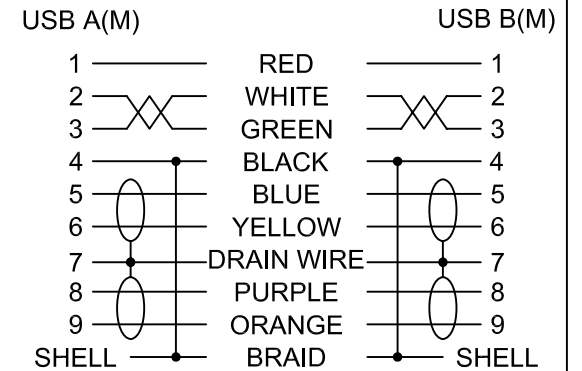

No	MATERIALS LIST:
1.	CABLE: 3 x (2 x 26 AWG)ST + 2 x 24 AWG O.D.:8.0mm COLOR:BLACK
2.	CONNECTOR:USB 3.0 A/M, 9P, BLUE INSULATOR SOLDER TYPE, NICKEL PLATED SHELL
3.	CONNECTOR:USB 3.0 B/M, 9P, BLUE INSULATOR SOLDER TYPE, NICKEL PLATED SHELL
4.	PVC MOLDED HOUSING, BLACK COLOR
5.	ABS ASSEMBLY HOUSING, BLACK COLOR
6.	SCREW:#4x34.5 M2

Jargy part no.	Client part no.	Approved	SCALE	UNIT
CBL-RTD3SABBS-xm				mm
Drawing Name		Drawn	Date	REV.
USB 3.0 A to B Cable M/M				1.0

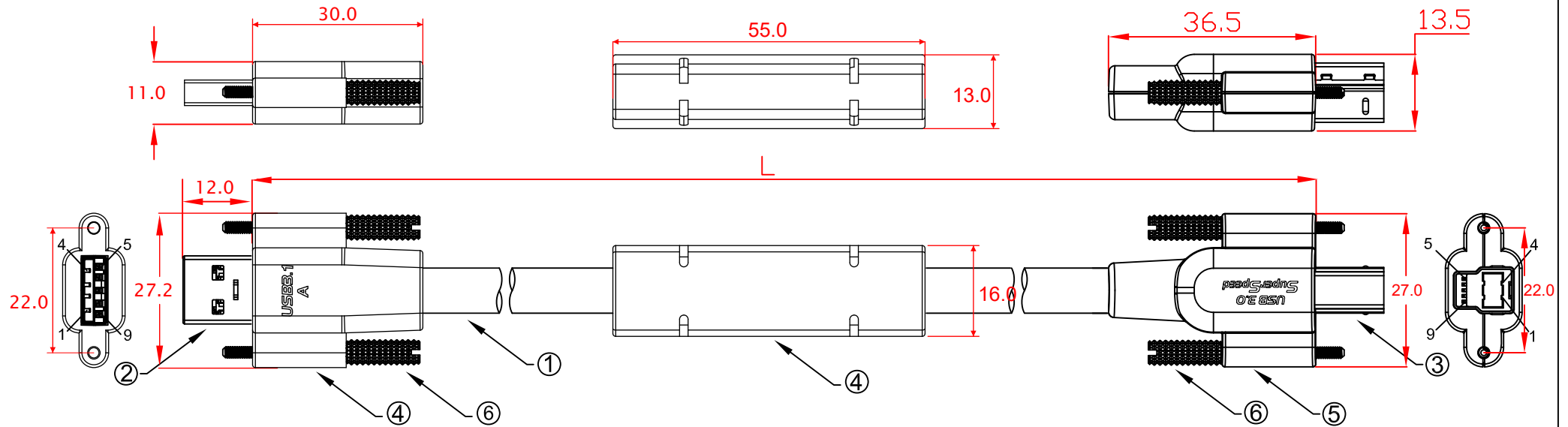

L:
 CBL-RTD3SABBSS-9m 9000mm±30mm
 CBL-RTD3SABBSS-10m 10000mm±30mm
 CBL-RTD3SABBSS-11m 11000mm±30mm
 CBL-RTD3SABBSS-12m 12000mm±30mm

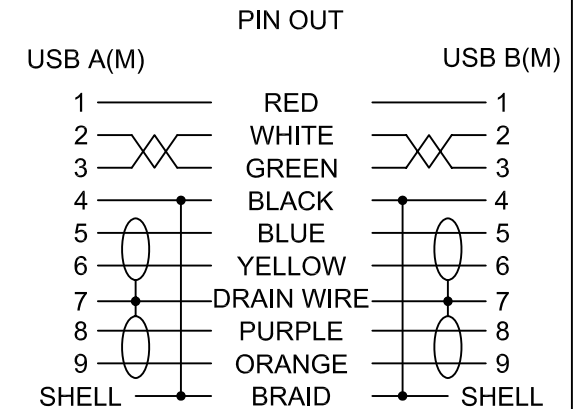

No	MATERIALS LIST:
1.	CABLE: 3 x (2 x 26 AWG)ST + 2 x 24 AWG O.D.:8.0mm COLOR:BLACK
2.	CONNECTOR:USB 3.0 A/M, 9P, BLUE INSULATOR SOLDER TYPE, NICKEL PLATED SHELL
3.	CONNECTOR:USB 3.0 B/M, 9P, BLUE INSULATOR SOLDER TYPE, NICKEL PLATED SHELL
4.	PVC MOLDED HOUSING, BLACK COLOR
5.	ABS ASSEMBLY HOUSING, BLACK COLOR
6.	SCREW:#4x34.5 M2

Jargy part no.	Client part no.	Approved	SCALE	UNIT
CBL-RTD3SABBSS-xm				mm
Drawing Name		Drawn	Date	REV.
USB 3.0 A to B Cable M/M				1.0